

Clearance for:
 "E" = 3/8" Screw
 "M" = M10 Screw

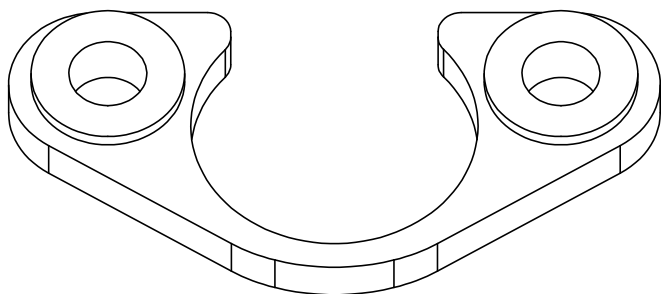
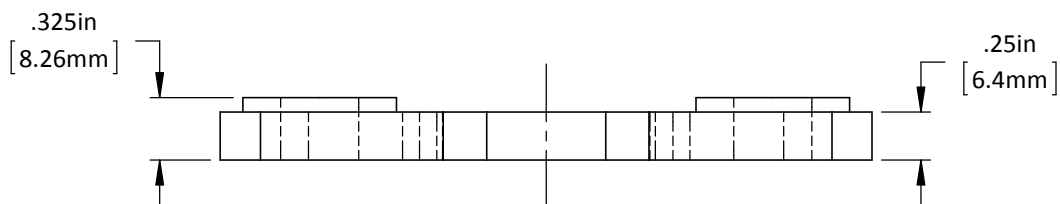
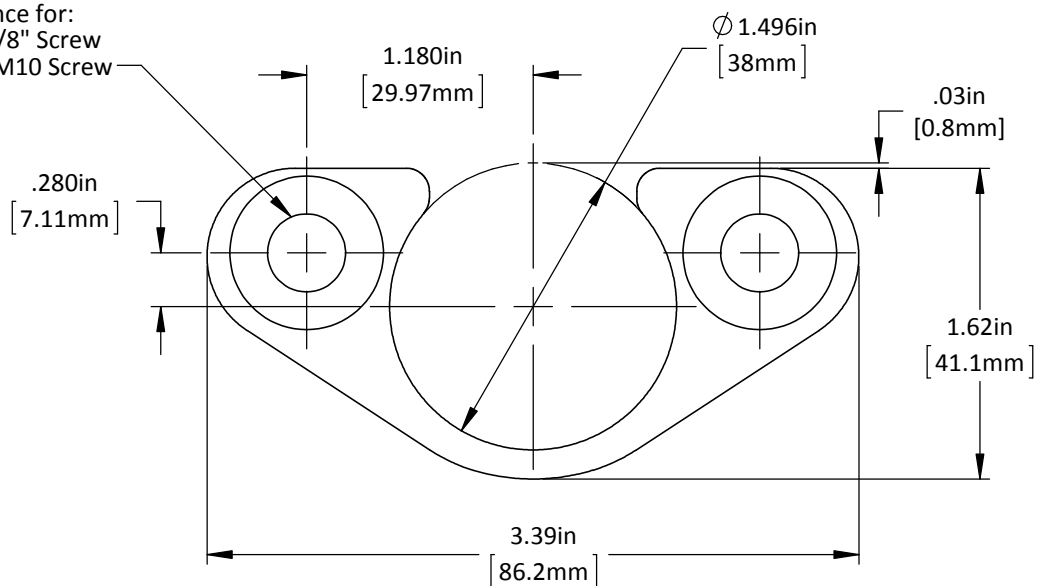

DO NOT SCALE DRAWING

REV 1

This product may be covered by one or more patents or patent applications.
 See <http://www.standardlifters.com/patents.html> for details.

Gas Spring Clamp-GSC-38-C

STANDARD LIFTERS INC

*Recommended Minimum Hole Size to be
Cylinder Body Diameter +1mm [.04"]

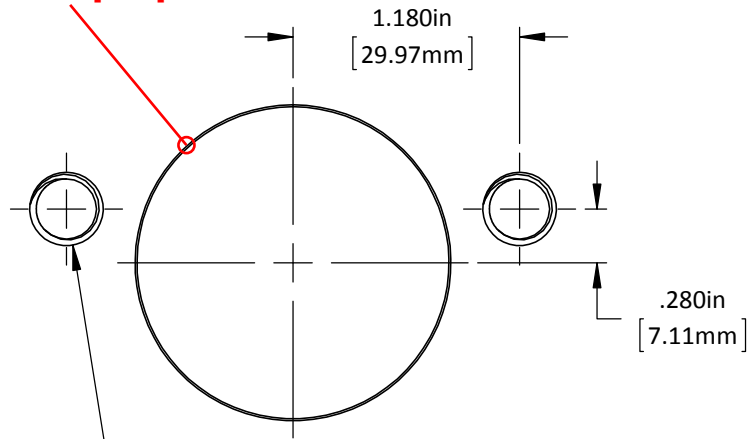

"E" = 3/8"-16 Tap X .75in Dp.
"M" = M10-1.50 Tap X 20mm Dp.
(2) Plcs.

DO NOT SCALE DRAWING	REV 1
This product may be covered by one or more patents or patent applications. See http://www.standardlifters.com/patents.html for details.	

Gas Spring Clamp-GSC-38-C-Machining
STANDARD LIFTERS INC