

DO NOT SCALE DRAWING

REV 2

Pilot-PA-13mm-1.9mm-S-R-F-Machining

This product may be covered by one or more patents or patent applications.
See <http://www.standardlifters.com/patents.html> for details.

STANDARD LIFTERS INC

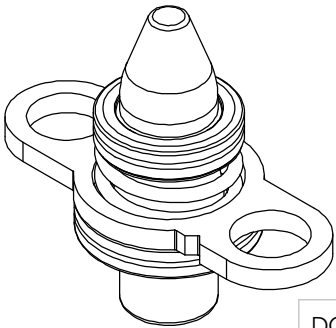
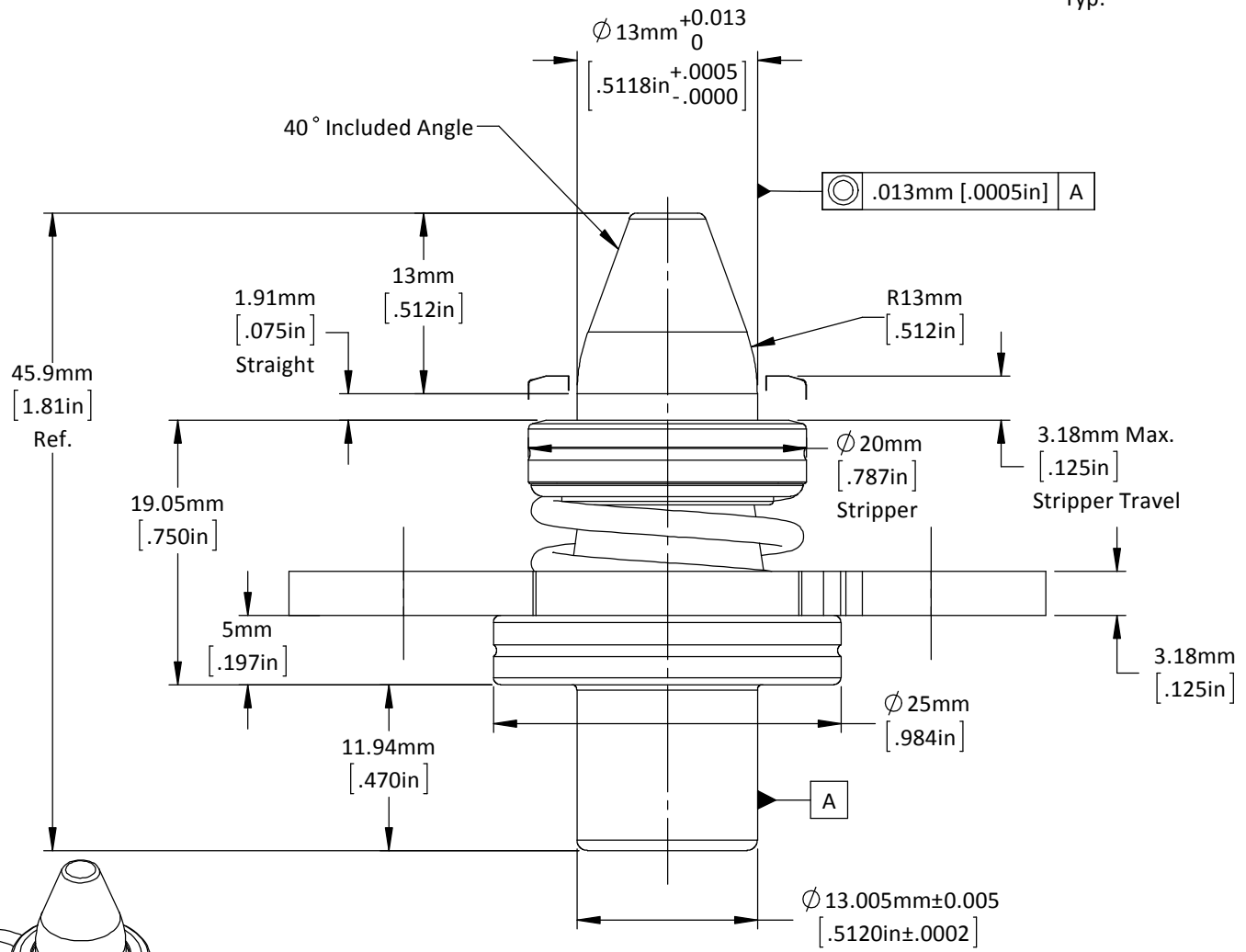
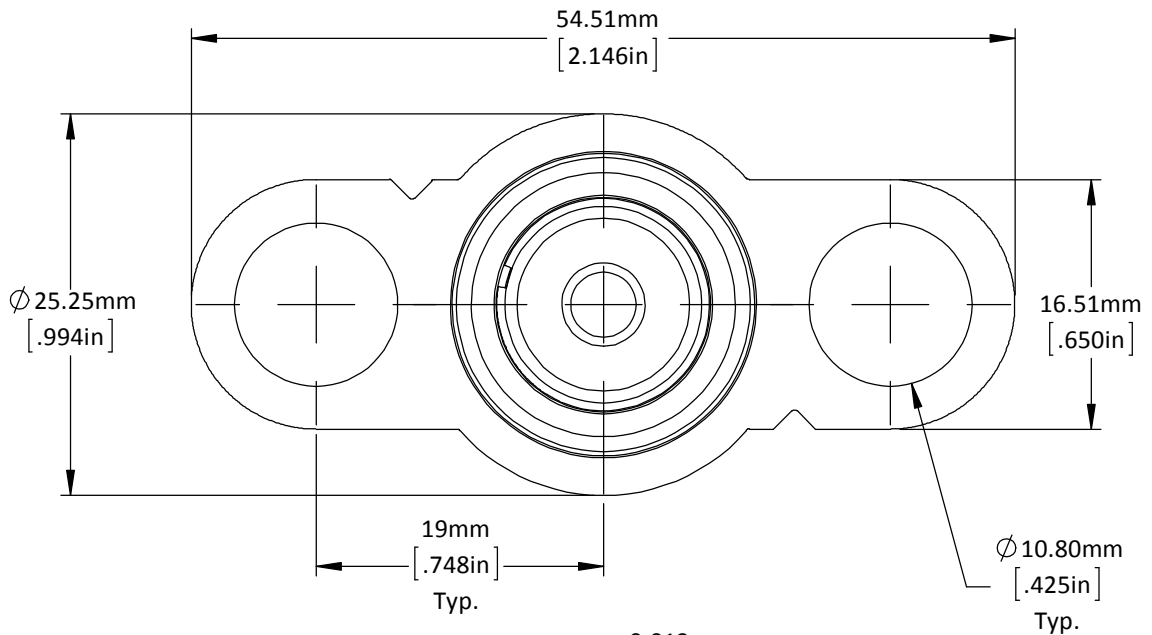

DO NOT SCALE DRAWING REV 1

This product may be covered by one or more patents or patent applications.
See <http://www.standardlifters.com/patents.html> for details.

Pilot-PA-13mm-1.9mm-S-R-F

STANDARD LIFTERS INC