

SECTION A-A

DO NOT SCALE DRAWING	REV 1	PE-25mm-16mm-S-A-Machining STANDARD LIFTERS INC
This product may be covered by one or more patents or patent applications. See http://www.standardlifters.com/patents.html for details.		

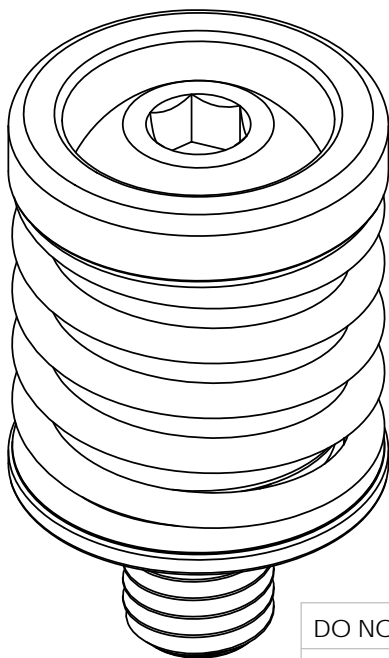
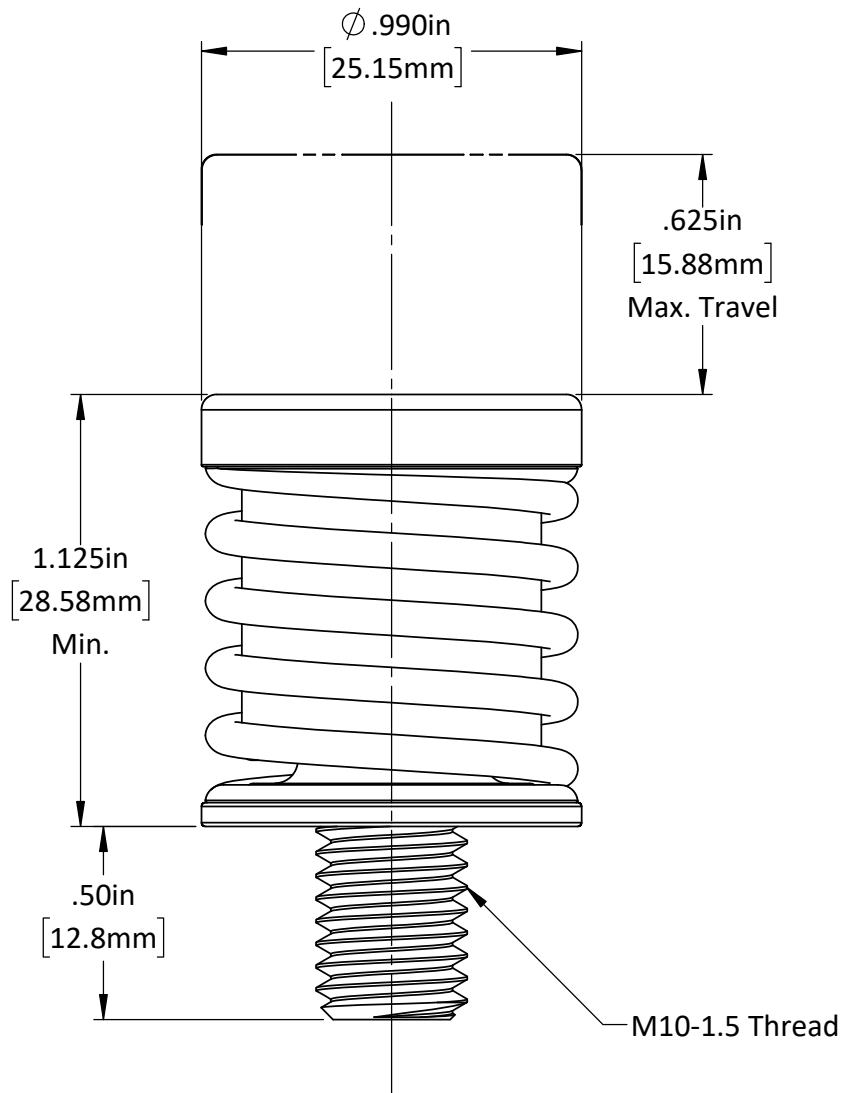
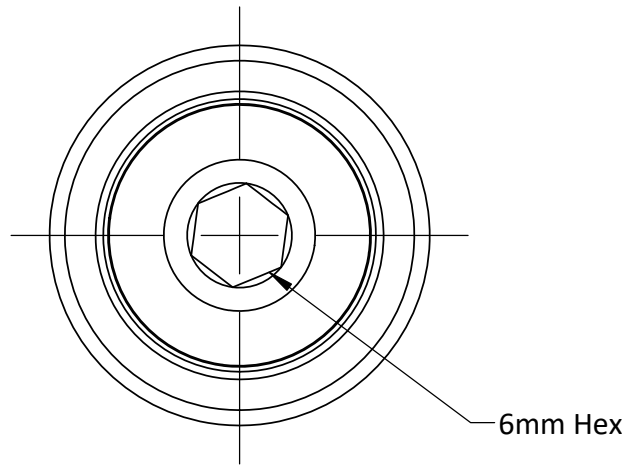

DO NOT SCALE DRAWING REV 1

This product may be covered by one or more patents or patent applications.
See <http://www.standardlifters.com/patents.html> for details.

PE-25mm-16mm-S-A

STANDARD LIFTERS INC