

**\*Caution: English & Metric Hole Locations are NOT the Same!**

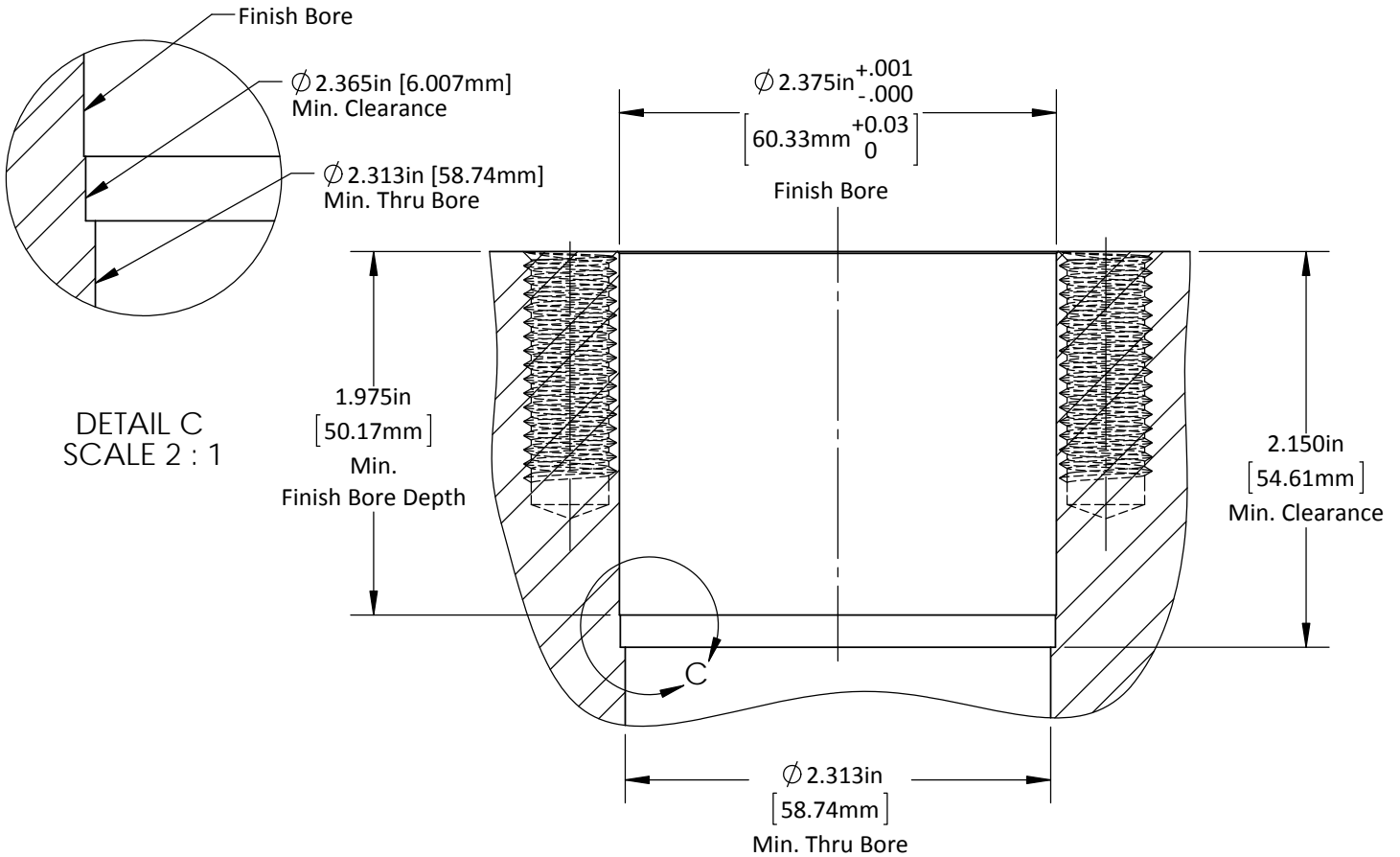
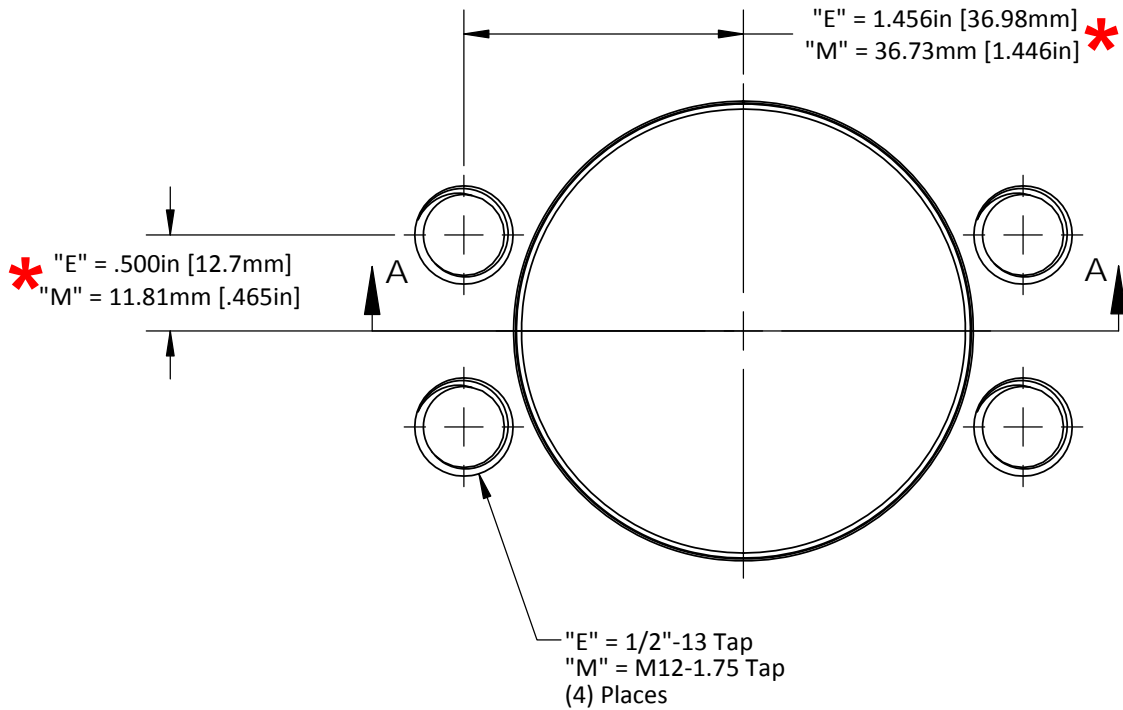

DO NOT SCALE DRAWING

REV 2

This product may be covered by one or more patents or patent applications.  
See <http://www.standardlifters.com/patents.html> for details.

**GK180-L3-Base Machining**

**STANDARD LIFTERS INC**

**\*Caution: English & Metric Hole Locations are NOT the Same!**

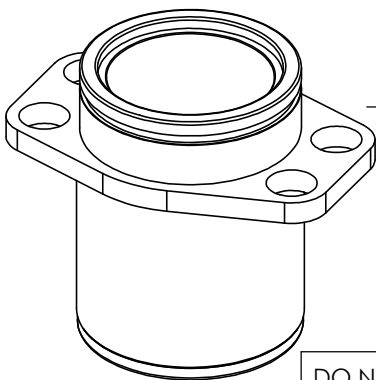
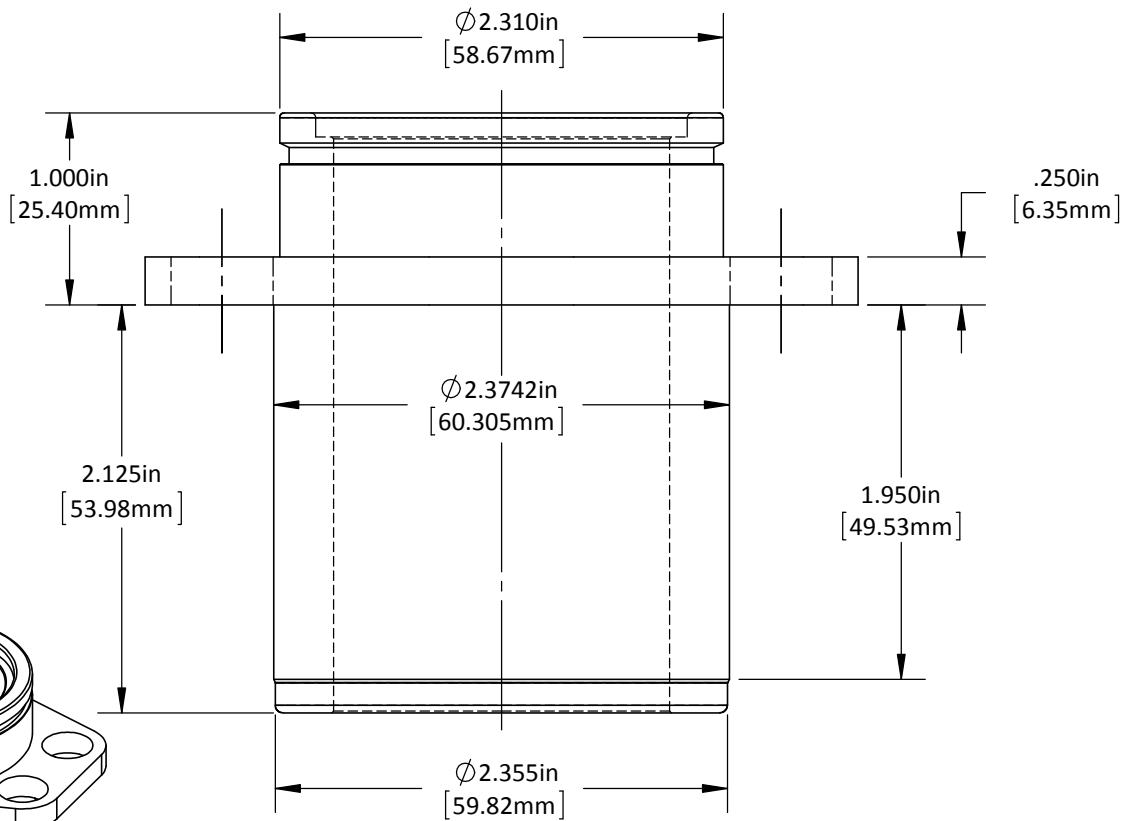
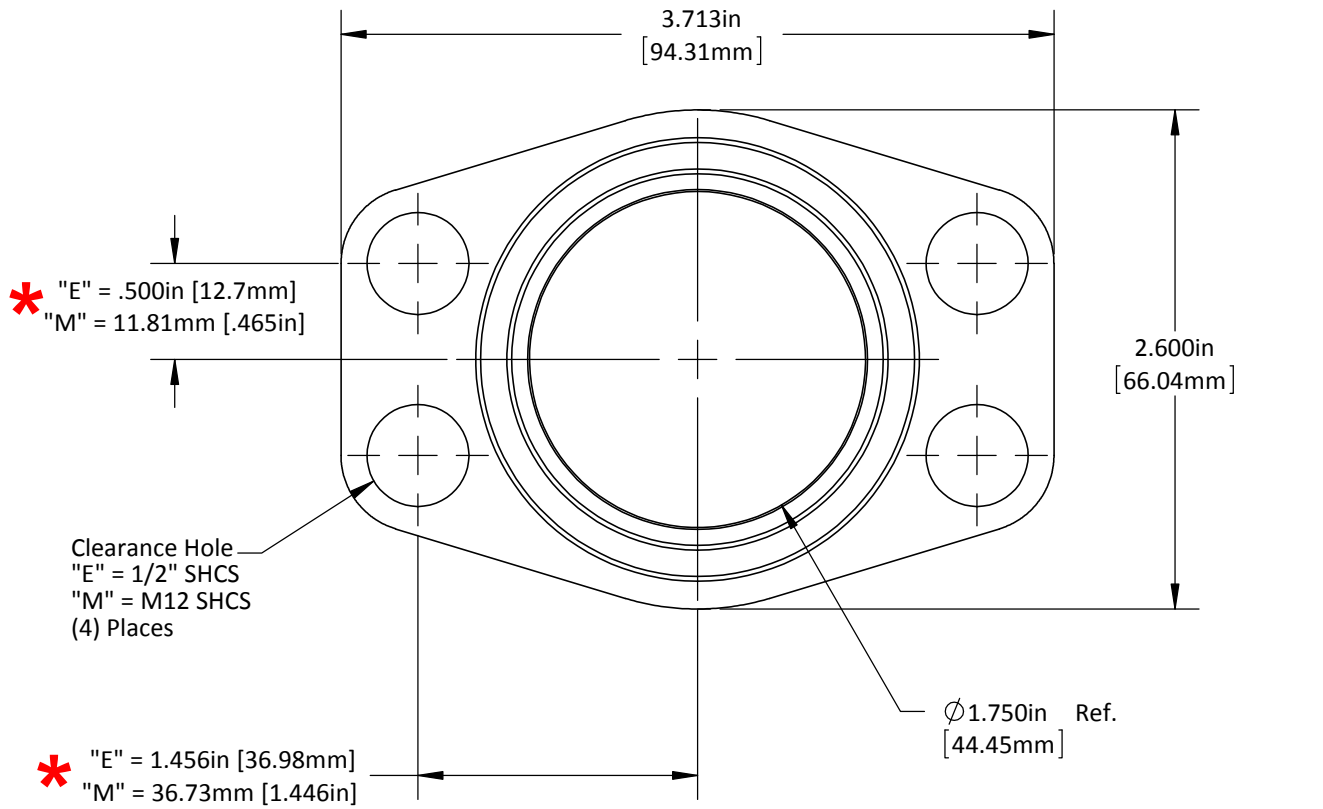

DO NOT SCALE DRAWING

REV 1

This product may be covered by one or more patents or patent applications. See <http://www.standardlifters.com/patents.html> for details.

**Base-GK180-L3**

**STANDARD LIFTERS INC**